

In aspiring to perfection



**JSC “Kharkov Tractor Plant  
named after S. Ordzhonikidze”**

# KHARKOV TRACTOR PLANT (XTZ)

- Kharkov Tractor Plant (XTZ) has been and still is the only enterprise in Post-Soviet space which produce serially wheeled and tracked techniques at the same time.
- There are 3300 people work in Kharkov Tractor Plant. The Plant's square is 143 ha. XTZ manufacture unites about 300 enterprises and organizations. Staff number is about 90 thousand people which are involved into manufacturing cycle of XTZ tractors production.
- XTZ dealer network accounts more than 120 companies.
- Nowadays the tractors of XTZ brand are famous all over the world, have proven themselves and are in demand not only in Ukraine, Kazakhstan and Russia but in external market such as Asia, America, Africa, Europe.



# XTZ MANUFACTURING AREA



## Auxiliary manufacture:

- Mechanical processing Shop #1
- Mechanical processing Shop #2
- Thermic Shop
- Pressing and Welding Shop
- Test Experimental Shop
- Tool Shop
- Pattern Shop
- Transport Shop
- Railway Shop
- Electric Power Shop
- Energy Shop
- Non-standard equipment Shop
- Accessories and Shipping Shop

## Main manufacture:

- Iron Foundry Shop
- Steel Casting Shop
- Forging Shop
- Mechanical Assembly Shop
- Assembly Shop (main conveyor)



# Main manufacture

## **Iron Foundry Shop:**

Activity direction: Casing iron-cast mouldings production such as gearbox casing, reduction gear casing, capacity pick shaft, transfer box casing etc.



## **Steel Casting Shop:**

Activity direction: The foundry for serial manufacture, sided foundry, colored foundry, moulding foundry.



## **Forging Shop:**

Activity direction: Blacksmithing work of any kind, details forging. Blank producing is maximally closed to finished component configuration. Blank producing from fast cutting steels. Thermic processing of details. Stamp equipment producing. Blank cutting.



# Main manufacture

## Assembly Shop:

Activity direction:  
tractors line assembling,  
tractors running and handing  
over, cab assembling plots,  
gearboxes, power takeoff shaft.



## Mechanical Assembly Shop:

Activity direction:  
details mechanical processing,  
electroplating, painting, assembling  
such as traction hook, clutch casing,  
bushings, shafts, pinions.  
The Shop produces the products of  
serial and special manufacture.



# Current model row of tractors:

## Of general destination



XTZ-150K-09-25

## Tillable ones



XTZ-16131-03  
XTZ-16131-05

## Tracked ones



T-150-05-09-25

## Compact ones



XTZ-3512

## Loaders



T-156B-09-03



XTZ-17221;  
XTZ-17021;  
XTZ-17221-19;  
XTZ-17221-21



XTZ-181



XTZ-2511-20



XTZ-17221-09

# Industrial technique on the basis of XTZ tractors



**XTZ -150K-09-15**  
(mulcher)



**KRT-1**  
(wheel-railed tractor)



**BKM-2M**  
(drilling-crane machine)



**T-150-05-09-25**



**XTZ -150K-09-25-06**



**UPM-1**  
(universal track machine)



**AS-42**  
(welding unit)



**TS10**



**XTZ -3512-09**

# Wheeled tractors of general destination

with 3<sup>rd</sup>-4<sup>th</sup> traction class:

**XTZ-150K-09-25, XTZ -17221, XTZ -17021,  
XTZ -17221-09, XTZ -17221-19, XTZ -17221-21**



Engine:

- YaMZ-236 (180 hp) - Russia
- Speed (forward/back), km/h - 30/9
- Traction effort, kg power - 3000-6000



Engine:

- YaMZ-236 (180 hp) - Russia
- YaMZ-238 (240 hp) - Russia
- DEUTZ (180 hp) - Germany
- D-260 (210 hp) - Belarus
- Speed (fw/back), km/h - 40/29
- Traction effort, kg power - 3000-6000



- Execution of energy-intensive agricultural works concerning the soil main processing.
- Crops and technical cultures seeding with high-grow sowing complexes.
- Transport operations with trailers and half-trailers of 20 tons loading capacity.
- The fertilizing, fodder preparation.

# Applying in operations

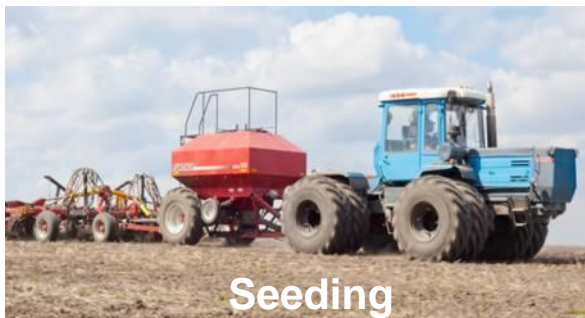
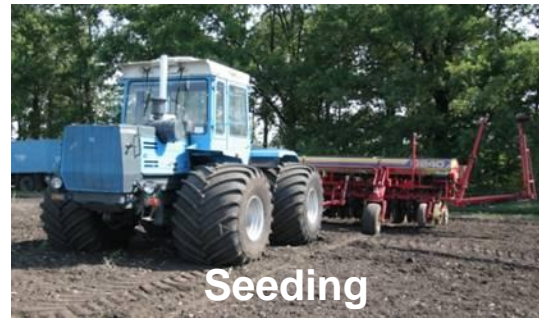

# Wheeled tillable tractors of 3<sup>rd</sup> traction class XTZ -16131-03 and XTZ -16131-05

- Execution of energy-intensive agricultural operations of general destination.
- Cultivation and harvesting of tilled crops.
- Combination of two and more operations concerning the cultivation and harvesting of agricultural crops.



Engine:  
DEUTZ (180 hp) - Germany  
D-260 (180 hp) - Belarus  
Speed (fw/back), km/h - 29/9  
Traction effort, kg power - 3000-6000



Plowing



Interrow cultivation



Tilled crops seeding



Haulm cleaning



Root crops harvesting



Tilled crops seeding with simultaneous fertilizing

# Crawler tractors of 4<sup>th</sup> and 5<sup>th</sup> traction classes T-150-05-09-25 and XTZ -181

- Execution of energy-intensive agricultural operations concerning soil processing.
- The plowing of average and heavy soils, early spring mulching.
- Disking, seeding, watering, harvesting.
- Fodder preparation and transport operations in off roads conditions.



Engine:  
 YaMZ-236 (180 hp) - Russia  
 Speed (fw/back), km/h - 15/8  
 Traction effort, kg power - 3000-6000



Engine :  
 YaMZ-238 (190 hp) - Russia  
 Speed (fw/back), km/h - 15/8  
 Traction effort, kg power - 4000-6000



# Tractors of low power with 0,6 traction class

## XTZ -2511-20 and XTZ -3512

- Mechanization of energy-intensive operations in agriculture, communal services, forestry and industrial manufacture.
- Transporting of different loads in trailers and half-trailers with loading capacity till 2 tones.



Engine:

D-120 (27 hp)

MMZ-3LD (35 hp)

Speed (fw/back), km/h

Traction effort, tone powers

- Russia  
- Belarus  
- 30/30  
- 0,6



Plowing



Cultivation



Harrowing



Crops seeding



Potatoes planting



Fodder preparation

# Frontal loaders

## T-156B-09-03

- Lifting, transportation, loading and discharging of loose and small chunks materials.
- Execution of earth-digging and road-construction operations.



Engine:  
YaMZ-236 (180 hp) - Russia  
Speed (fw/back), km/h - 35/16  
Loading capacity, tones - 3

# XTZ tractors updating

microclimate system with smooth adjustment of air temperature



audio system with loudspeakers (option)



new panel of devices, adjustable steering column



hydrotank of enlarged capacity, new pump of hydraulic system



amortization seat which is regulated under the weight and height of operator



doors with increased stiffness providing the cabin pressurization



new door knob and key lock of cabin which is located in



sliding window leaves in doors



4-ranged gearbox 16/8 with increased resource and guaranteed term till 1500 engine hours



Amount of hydraulic transmissions is increased to 4 pairs, 5-section proportional hydro sprayer with adjustable oil flow by sections, new hydraulic sleeves of high pressure

# Modernized gearbox

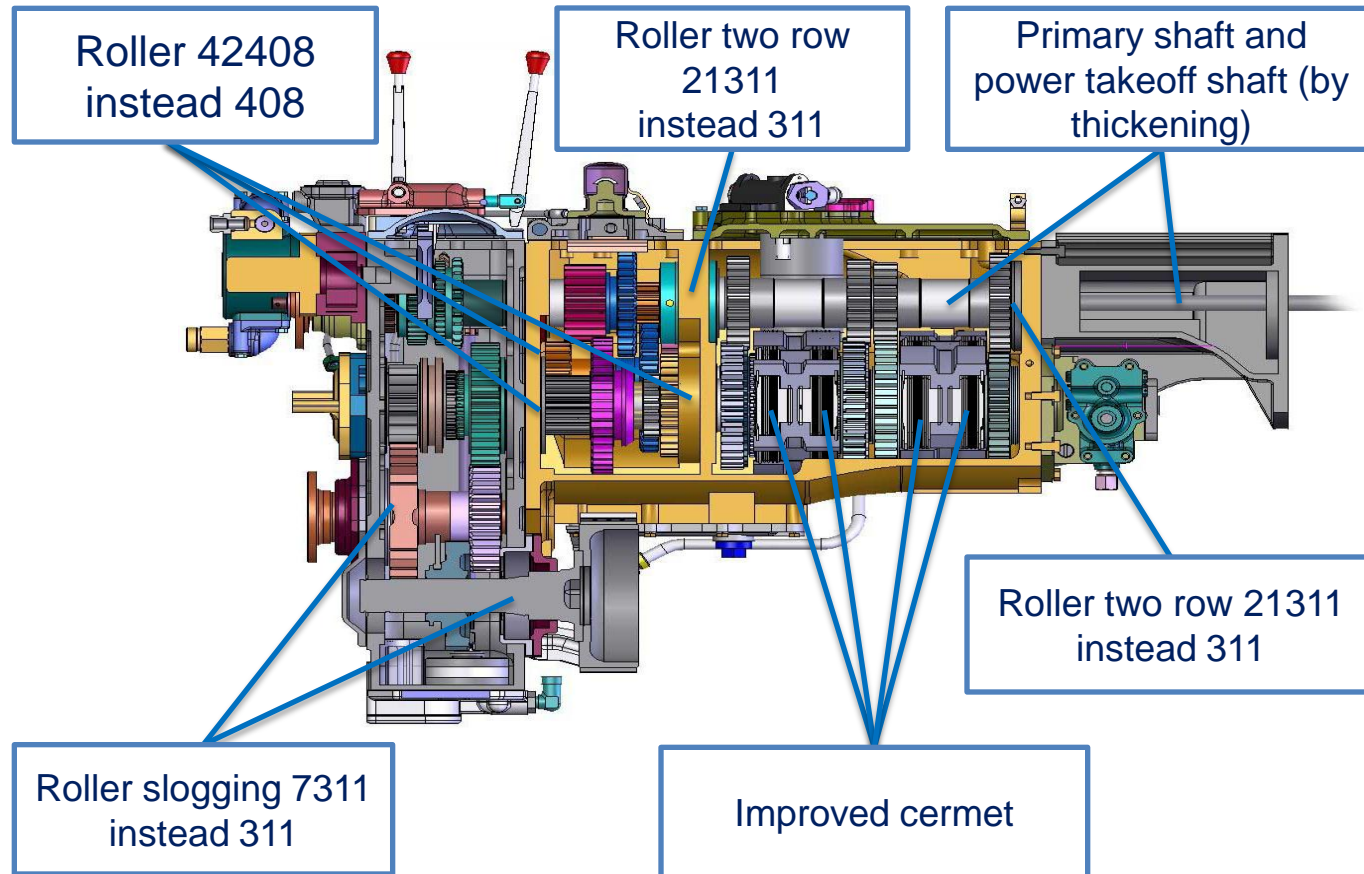

- Number of transmissions of ahead going is increased to 16 (instead of 12);
- Transport speed of the tractor is increased to 40 km/h;
- Gearbox realization of engine with 250 horse power capacity, instead of 210 hp before modernization;
- Guaranteed term of the service is increased to 1500 engine hours (instead of 1000 engine hours);
- Stock coefficient of hydraulic pressing clutches is strengthened in 1,5 times.

# Hydraulic and hinged systems

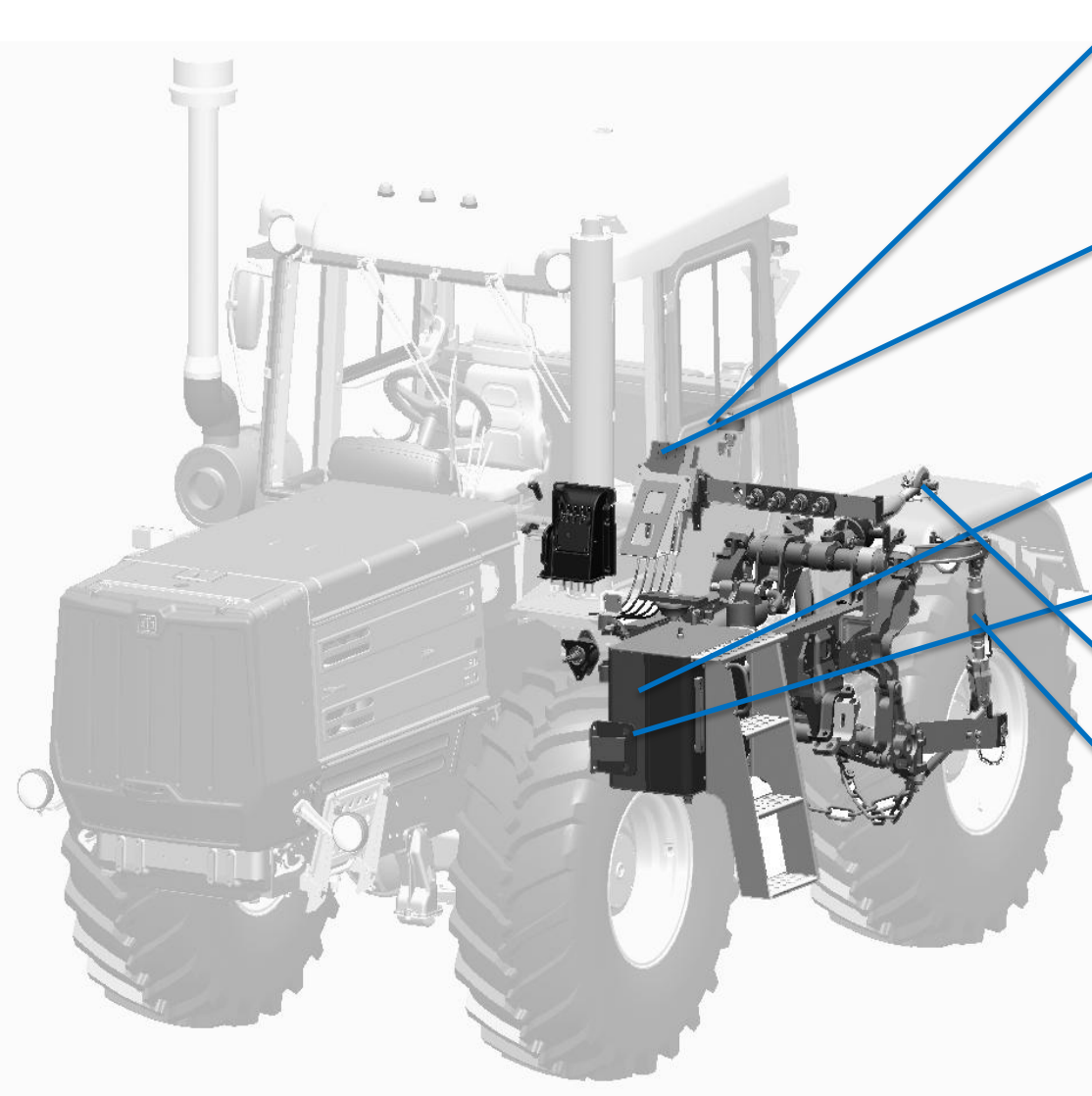

New breather

New 5-section hydro spreader with hawser driving  
Adjustable independent sections  
Two lines of LS-system

New gear pump Bondioli & Pavesi  
with 100 l/min of productivity

Combined, increased hydrotank with  
90 l of volume

Strengthened central traction and sloping  
strut (pipe 76x12)  
M42mm carvings are applied

# New modernized cabin

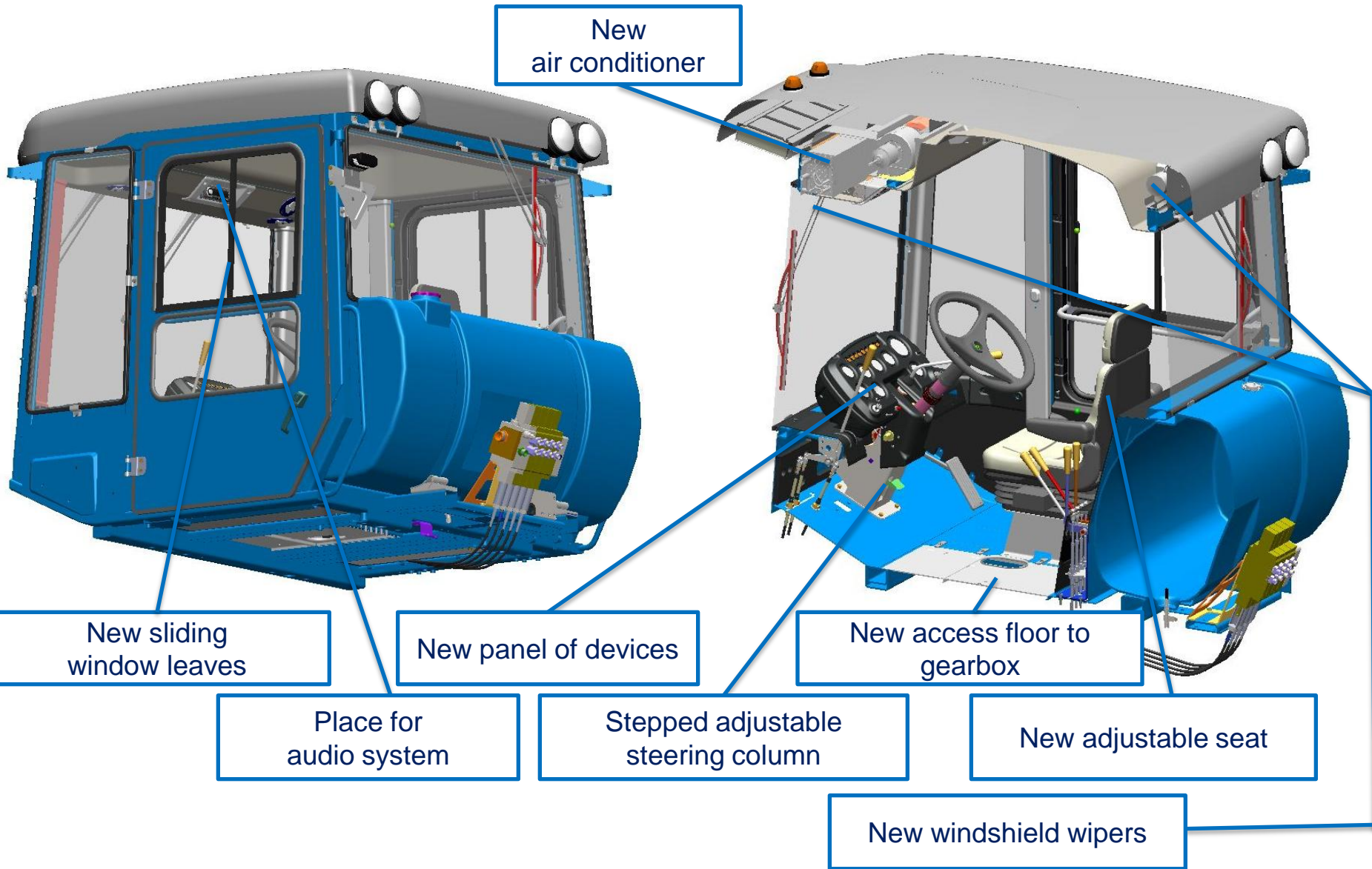



**Kharkov  
Tractor  
Plant**

**JSC «Kharkov Tractor Plant»  
275, Moskovsky Ave, Kharkov, 61007, Ukraine  
Tel: +38 0572 95 77 25, fax: +38 0572 94 17 60**

