

NEW 2014

SCHRÉDER ROAD + URBAN LIGHTING SOLUTIONS

Schröder





ROAD & URBAN LIGHTING SOLUTIONS FOR ROAD AND URBAN ENVIRONMENTS



SAFETY

An efficient lighting that provides the right light at the right time in the right place allows people to avoid obstacles, to see and be seen, prevents accidents and eases travel for emergency services. An interactive monitoring system can detect failures to isolate repairs and facilitate maintenance operations to ensure a performing lighting network at all times.



WELL-BEING

Making the roads, highways and streets safe and comfortable, with traffic flowing freely both by day and by night, increases the well-being of users. Schröder solutions can help prevent accidents and traffic jams so that people spend less time in transit and more time on other activities. This results in an improved quality of life for the population and benefits the local economy.



SUSTAINABILITY

Preserving the environment is a collective obligation. Schröder uses recyclable materials for its efficient solutions. In addition, the remote management system includes a troubleshooting analysis to provide crucial information for managing maintenance operations in the most sustainable way, avoiding unnecessary long distance travel.



SAVINGS

Schröder is constantly using the upmost technological innovations - including high performing LEDs and advanced control systems - to provide lighting solutions with maximum performance without compromising on quality. With this tremendous efficiency, a long lifespan and limited maintenance requirements, they enable you to minimise your total cost of ownership and provide a short payback time.

SOLUTIONS FOR THE RIGHT LIGHT WITH ABSOLUTE SAFETY

Schröder provides full scope solutions from design to after-sales service, including lighting, intelligent control systems, street furniture, finance, security, signage and many other smart features.

In a road and urban environment, they offer a clear added-value to ensure safety and well-being for the users at all times while providing energy and maintenance savings.



1. OMNISTAR12



2. AMPERA MAXI + ANDO16



3. AMPERA MIDI + ITO16



4. NEOS ZEBRA 20



5. YOA SIDE-ENTRY 24



6. YOA POST-TOP 24



7. PILZEO 28



DEXO 32



TECHNOLOGY TO SERVE YOU BETTER

LENOSFLEX®2: EFFICIENCY, FLEXIBILITY, SUSTAINABILITY AND PERFORMANCE

SCHRÉDER HAS SPECIFICALLY DEVELOPED SECOND GENERATION LENOSFLEX®2 PHOTOMETRIC ENGINES FOR LIGHTING SPACES IN A SUSTAINABLE AND EFFICIENT WAY, TO GENERATE SAVINGS BOTH IN TERMS OF TOTAL COST OF OWNERSHIP AND CO₂ EMISSIONS.

The LensoFlex®2 builds on the flexibility offered by a selection of lenses. To perfectly meet the needs of each kind of place to be lit, Schröder has designed a large range of photometries.

This concept is based upon the addition principle of photometric distribution. Each LED is associated with a specific lens that generates the complete photometric distribution of the luminaire. It is the number of LEDs in combination with the driving current that determines the intensity level of the light distribution.

The LensoFlex®2 concept has been used by Schröder as a platform to build a state-of-the-art range of LED lighting solutions that provide significant energy savings and offer flexibility both in terms of performance and control while ensuring a long lifespan.



LENOSFLEX®2 LED COMBINATIONS: FLUX, CURRENT AND POWER CONSUMPTION

LENOSFLEX®2

Number of LEDs	Neutral white (4,250K) ⁽¹⁾	LENOSFLEX®2											Lifetime residual flux @ t _q 25°C ⁽⁴⁾									
		16 LEDs	24 LEDs	32 LEDs	40 LEDs	48 LEDs	56 LEDs	64 LEDs	72 LEDs	80 LEDs	88 LEDs	96 LEDs		104 LEDs	112 LEDs	120 LEDs	128 LEDs	136 LEDs	144 LEDs	192 LEDs	240 LEDs	288 LEDs
Current: 350mA	Nominal flux (lm) ⁽²⁾	2200	3400	4500	5700	6800	8000	9100	10200	11400	12500	13700	14800	16000	17100	18300	19400	20500	27400	34300	41100	90%
	Power consumption (W) ⁽³⁾	18	27	36	44	53	62	70	78	86	94	102	116	124	132	140	147	155	208	257	311	
Current: 500mA	Nominal flux (lm) ⁽²⁾	3000	4500	6000	7500	9000	10550	12000	13500	15100	16600	18100	19600	21100	22600	24100	25600	27100	38400	48000	-	80%
	Power consumption (W) ⁽³⁾	26	38	51	63	75	87	99	111	122	134	146	163	174	186	198	210	221	309	391	-	
Current: 700mA	Nominal flux (lm) ⁽²⁾	3800	5800	7700	9700	11600	13600	15500	17500	19400	21300	23300	25200	27200	29100	31100	-	-	-	-	-	80%
	Power consumption (W) ⁽³⁾	36	55	71	90	107	123	139	163	180	196	213	229	245	262	279	-	-	-	-	-	

⁽¹⁾ Warm white (3100K) and cool white (6200K) available. All with a CRI>70.

⁽²⁾ The nominal flux is an indicative LED flux @ t_j 25°C based on LED manufacturer's data. The real flux output of the luminaire depends on environmental conditions (e.g. temperature and pollution) and the optical efficiency of luminaire. Nominal flux depends on the type of LED in use and likely to change in accordance with the continuous and rapid developments in LED technology.

⁽³⁾ The power consumption is an indication and may vary from luminaire to luminaire.

⁽⁴⁾ After 100,000 hours at a driving current of 350 or 500mA, the luminaire maintains 90% of its initial luminous flux. When functioning under 700mA, the luminaire maintains 80% of its initial luminous flux after the same period of 100,000 hours. These indicative figures are based on IES LM-80 - TM-21. They are valid when the average performance temperature (T_q) did not exceed 25°C and the maximum ambient temperature (T_a) for the luminaire is respected.

Note: Certain values may change. For more accurate information and to follow the progress of the luminous efficiency and lumen maintenance of the LEDs used, please visit our web site.

TYPICAL LIGHT DISTRIBUTIONS

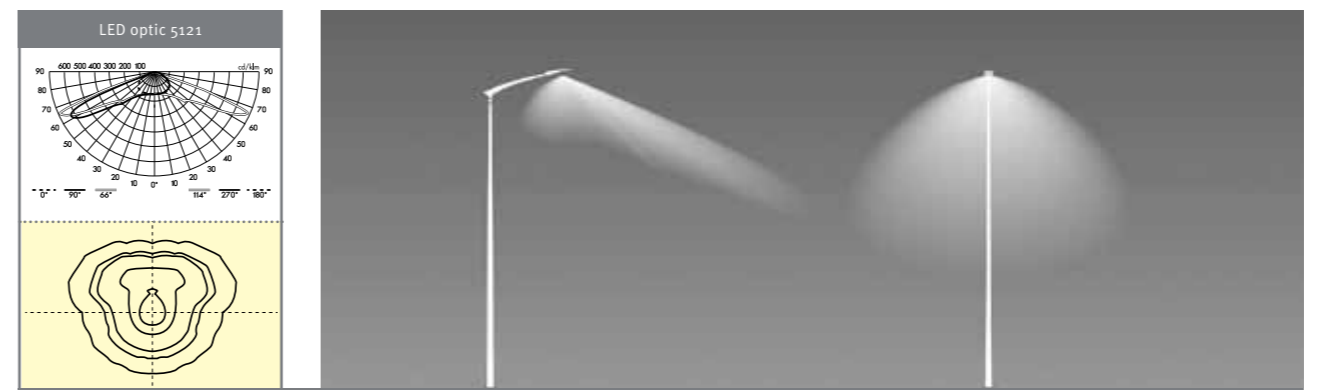
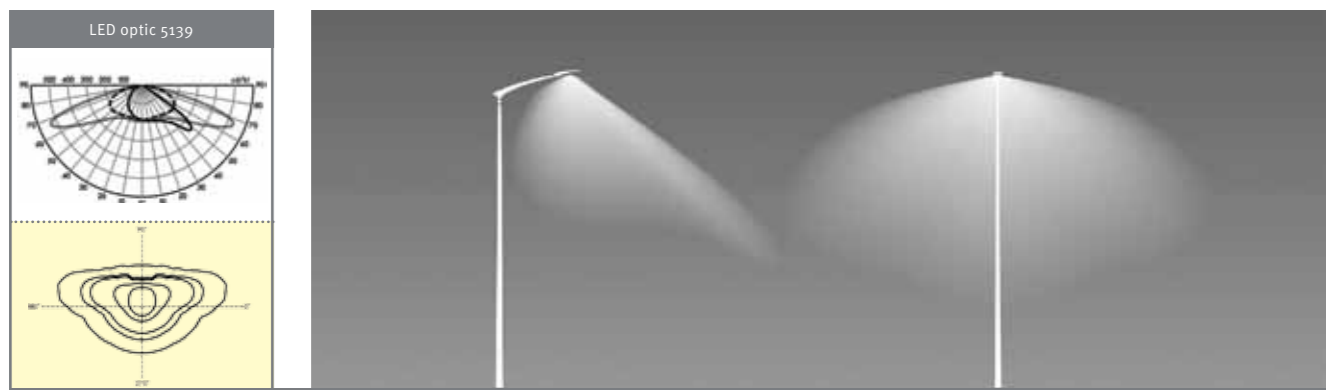
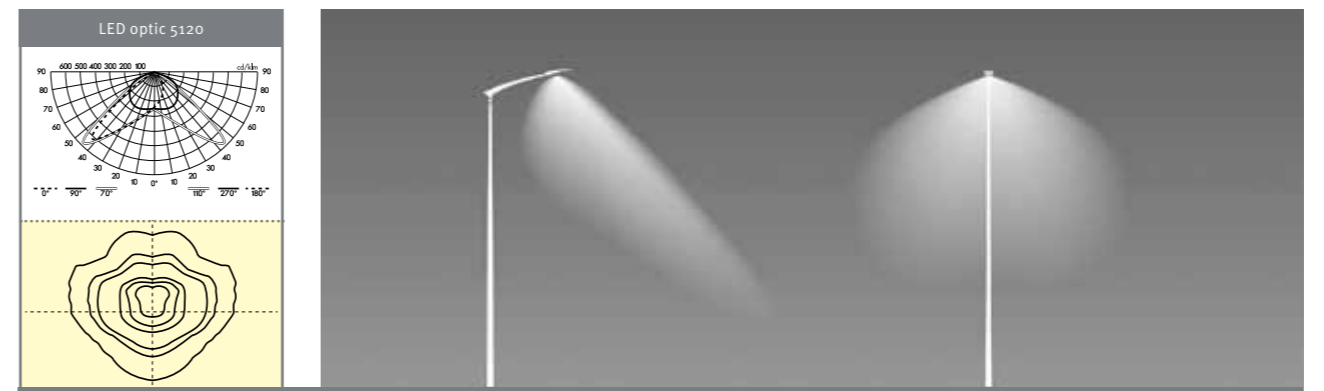
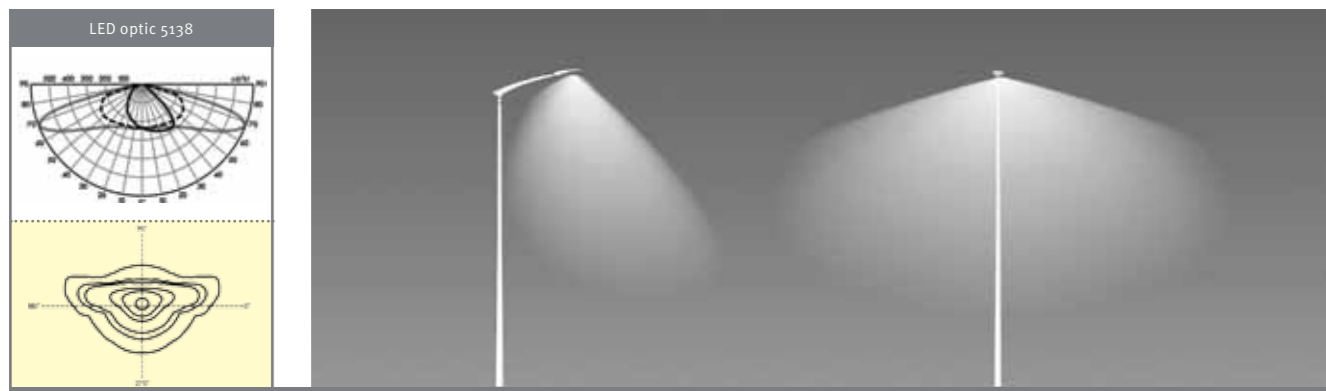
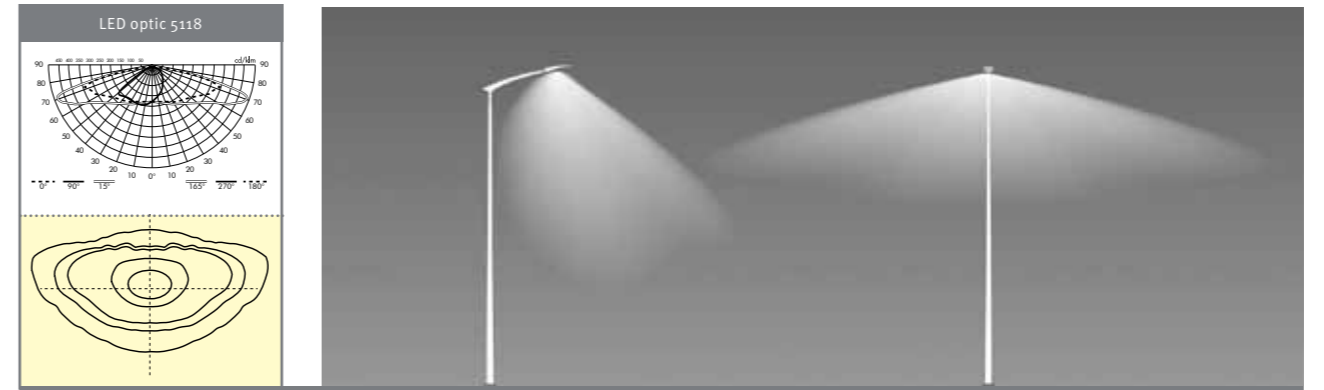
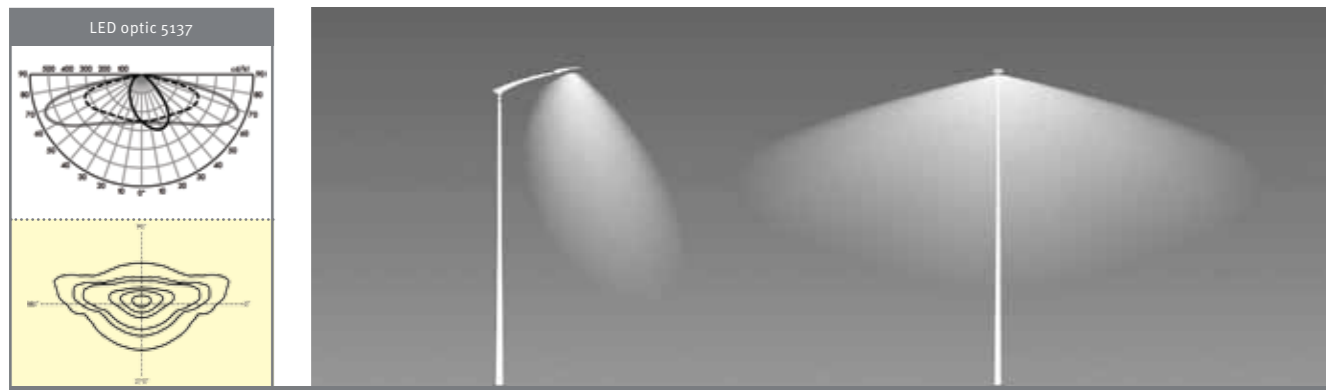
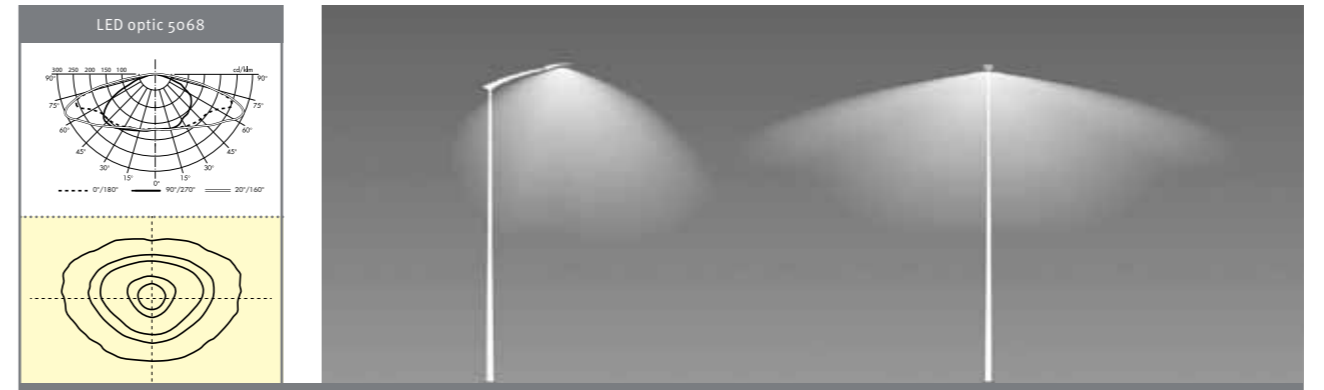
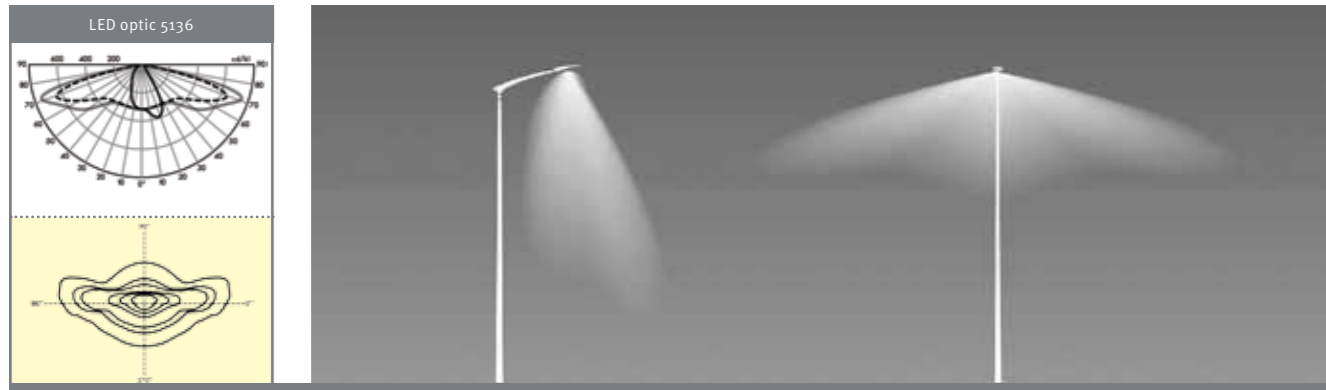

For more light distributions, please visit our web site or contact your local sales representative.



Owlet CONTROL SOLUTIONS

READY TO BE A SMART CITY?

One of the major concerns for cities is the reduction of public expenditure. A large chunk of this spending goes on energy bills, with public lighting accounting for 40% of the total. Thanks to Owlet, the smart control solutions offered by Schröder, cities and building managers can reduce their energy bills by up to 85%. In addition, they manage expenses more efficiently, improve maintenance and asset management and provide increased safety with enhanced well-being for their citizens.



OWLET OFFERS 3 TYPES OF CONTROL SOLUTIONS, FROM BASIC TO ADVANCED

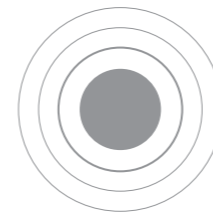

STAND-ALONE SOLUTIONS

RECOMMENDED FOR BASIC SMART LIGHTING

Each luminaire is fitted with a control unit and can be managed independently. This type of control system is ideal for areas with little activity at night such as pedestrian areas, parks, car parks and warehouses. Owlet stand-alone solutions encompass:

- **intelligent drivers** with features such as an astronomical clock for a constant adaptation of the dimming profile, constant light output to eliminate overlighting and scheduled dimming with multi-level programmes;
- integrated **photocells** to switch the luminaire on or off following the level of natural light;
- **motion and speed detection** sensors that enable interactive dimming.

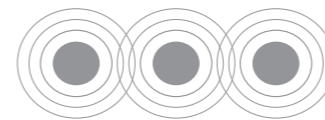

AUTONOMOUS NETWORK

RECOMMENDED FOR RESPONSIVE AREAS

The Autonomous Network Dimming system enables **luminaires to communicate together in a wireless network** to provide dynamic profile dimming. The dimming profile can easily be changed by simply connecting wirelessly a laptop to one luminaire without using any tools. The new configuration will be deployed to all the luminaires in the network. This system can be enhanced with motion and speed detection sensors. When motion is detected, the detection scenario supplants the dimming scenario to provide safety and comfort for users. The sensors can be centralised or decentralised. Each luminaire is fitted with a control unit and can be managed independently. The autonomous network is perfectly suited to streets, roads, squares, parks, sport fields etc.

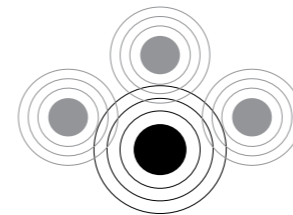

INTEROPERABLE NETWORK

RECOMMENDED FOR ENTIRE LIGHTING INSTALLATIONS
(ROADS, STREETS, TUNNELS,...)

The Schröder Owlet Nightshift is a remote control system for monitoring, metering and managing a lighting network. **It is a unique combination of state-of-the-art technology and an easy-to-use web interface to control each luminaire at all times from anywhere in the world.** Thanks to bi-directional communication, the operating status, energy consumption and possible failures can be monitored. Thanks to its open source Zigbee technology and its flexible MySQL workflow, the Nightshift system can easily be associated to third party systems through data bridges. This flexibility increases the functionalities far beyond lighting.

SMART DRIVERS

INTELLIGENCE AND FLEXIBILITY TO SAVE ENERGY

SCHRÉDER LED SOLUTIONS INCORPORATE DRIVERS THAT INTEGRATE A LOT OF SMART FEATURES TO AVOID UNNECESSARY LIGHTING TO REDUCE YOUR ENERGY EXPENSES.

BI-POWER FUNCTIONALITY

In some countries, a control wire or switched line is distributed throughout the street lighting network.

When the street lighting is switched on, both the line and the switched line are energised to the 230V level. During the night, this switched line is switched off from the grid. The bi-power driver detects this signal as a command to reduce the output current to a lower preset value, usually 50%.

This procedure is common practice for luminaires fitted with traditional discharge lamps but generates little savings. However for LED equipped luminaires, the decrease in energy consumption is almost linear to the decrease in light output.

This basic dimming method lacks flexibility, but generates considerable energy savings for night-time periods when less light is required.

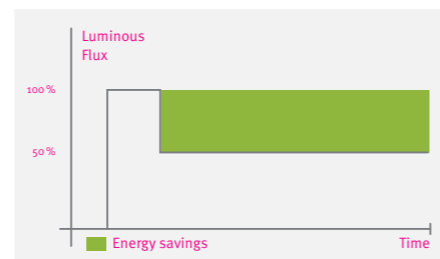

PROGRAMMABLE OUTPUT CURRENT

Traditional light sources offered a limited choice in power to achieve the required lighting levels resulting in some streets being over lit. For example, a 150W lamp would be installed even if 115W was sufficient to achieve the necessary lighting level.

The combination of LEDs and intelligent programmable drivers makes it possible to adjust the output current to obtain the absolute flux level required for a given application. As a consequence, energy consumption and spill light are further reduced.

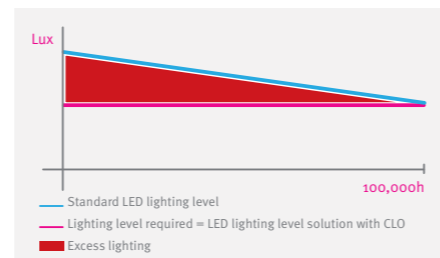

CONSTANT LIGHT OUTPUT (CLO)

Constant Light Output (CLO) compensates for the depreciation of luminous flux over time and avoids excess lighting at the start of an installation's service life. In fact, the luminous depreciation that takes place over time, is taken into account to ensure a predefined lighting level during the luminaire's useful life.

Without a CLO feature, the initial power upon installation would be increased to make up for luminous depreciation. By precisely controlling the luminous flux, the energy is controlled to provide the required level - no more, and no less - throughout the luminaire's life.

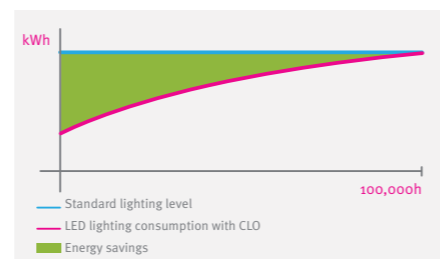

CUSTOM DIMMING PROFILE

Intelligent drivers can be programmed in the factory with complex dimming profiles. Up to 5 combinations of time intervals and light levels are possible. This feature does not require any extra wiring.

This customised dimming system generates maximum energy savings while respecting the required lighting levels and uniformity throughout the night.

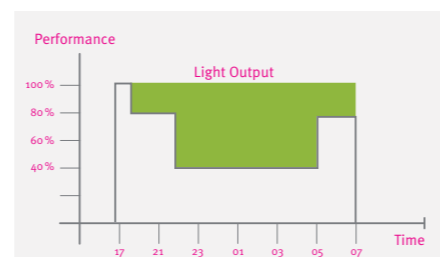

CONTROL

AS EASY AS SURFING THE INTERNET

FROM BEHIND YOUR COMPUTER OR YOUR MOBILE DEVICE, YOU CAN MANAGE YOUR LIGHTING INSTALLATION VIA YOUR WEB BROWSER. THE USER-FRIENDLY INTERFACE IS VERY INTUITIVE AND EASY-TO-USE.

JOIN THE OWLET MOVEMENT!

LIKE SAN JOSÉ, CALIFORNIA - CAPITAL OF SILICON VALLEY, CRADLE OF THE DIGITAL REVOLUTION - NUMEROUS CITIES ALL OVER THE WORLD TRUST THE OWLET SOLUTIONS TO ACHIEVE THEIR AMBITIOUS TARGETS OF REDUCING CO₂ EMISSIONS AND ENERGY COSTS.

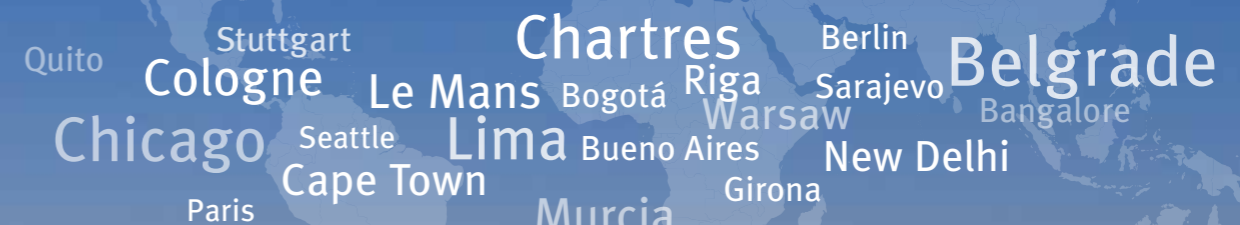

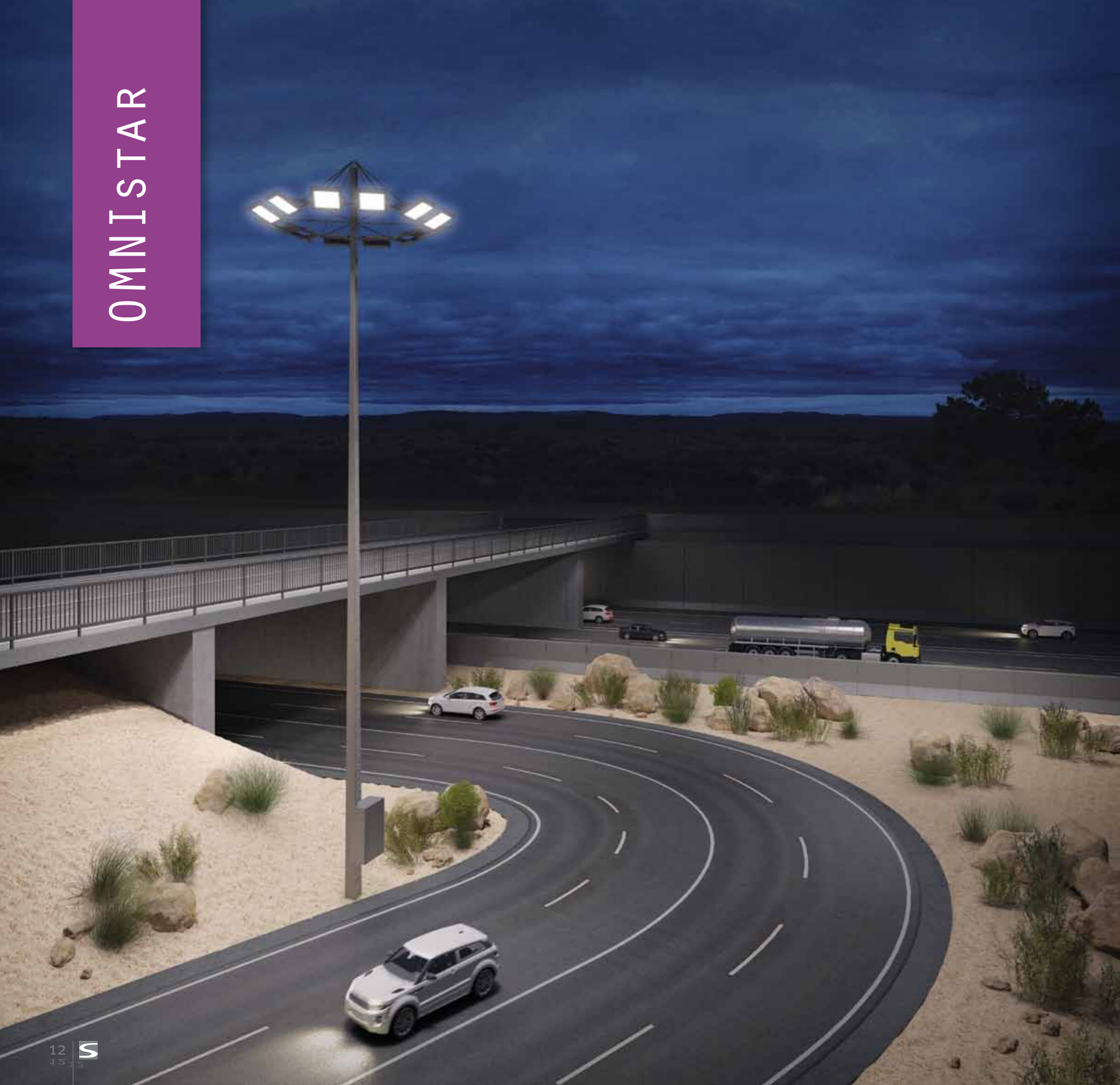

LED SOLUTION FOR HIGH-POWER APPLICATIONS

OMNISTAR IS SETTING A NEW STANDARD BY PROVIDING A REAL AND PERFORMING LED ALTERNATIVE TO HID LUMINAIRES FOR HIGH POWER APPLICATIONS SUCH AS MOTORWAY JUNCTIONS, SERVICE AREAS AND TOLL PLAZAS.

The OMNISTAR has been designed to provide an unrivalled combination of performance and flexibility for lighting areas where high lumen packages are needed (30,000 to 120,000lm) while offering maximum savings in energy and maintenance costs and a short payback time.

This modular luminaire can be installed on a high mast with a bracket of one, two or three luminaires to provide the lighting distribution and lumen package needed to meet the specifications of the area to be lit. With on-site photometric adjustment, the OMNISTAR guarantees the perfect lighting to ensure safety and comfort. It offers a real alternative to luminaires equipped with high power traditional sources, with the added advantages of an LED solution: low energy consumption, improved visibility with white light, limited maintenance and longer life.

The OMNISTAR can also be fitted with the Owlet range of control solutions to enable you to further maximise energy savings by adapting the light levels according to the real needs.



CHARACTERISTICS

Installation height	8 to 30m		
Lumen package range (nominal flux)	Mono 30,000 - 40,000lm	Duo 70,000 - 80,000lm	Trio 105,000 - 120,000lm
Colour temperature	Neutral white (Cool and warm white: optional)		
Optical compartment tightness level	IP 66 (*)		
Control gear tightness level	IP 66 (*)		
Impact resistance (glass)	IK 08 (**)		
Nominal voltage	120 - 277V - 50 - 60Hz		
Electrical class	US 1	EU I or II (**)	
Weight (without gear box)	15.6kg		
MATERIALS			
Body	High-pressure die-cast aluminium		
Protector	Glass		
Colour	AKZO grey 900 sanded Any other RAL or AKZO colour upon request		

(*) according to IEC - EN 60598 | (**) according to IEC - EN 62262

KEY ADVANTAGES

- Cost effective and efficient lighting solution to maximise energy and maintenance cost savings
- Modular approach for high-power applications
- Wide range of lighting distributions for multi-purpose applications
- Photometric adjustment on-site
- Surge protection 10kV
- IP 66 tightness level for long term performance

DIMENSIONS | MOUNTING

Mono	
L	532mm
H	530mm
W	80mm

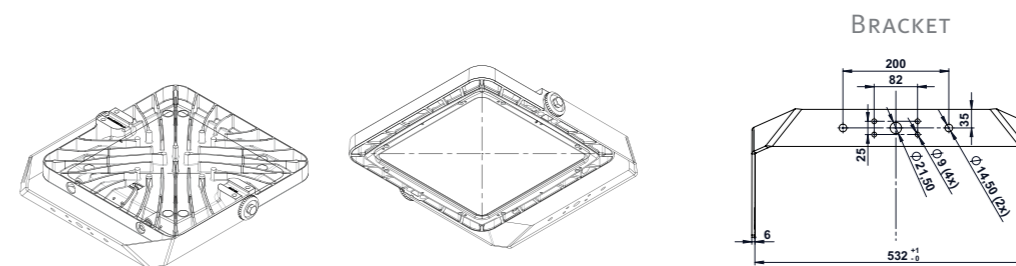
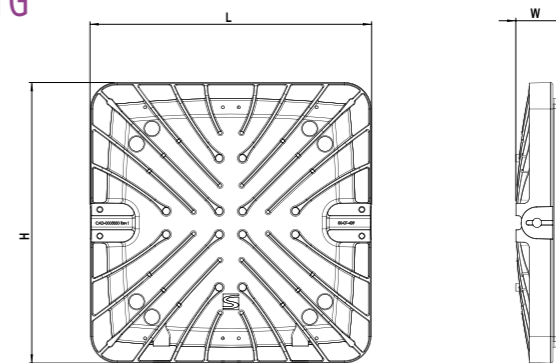

MONO + DRIVER BOX

DUO

TRIO

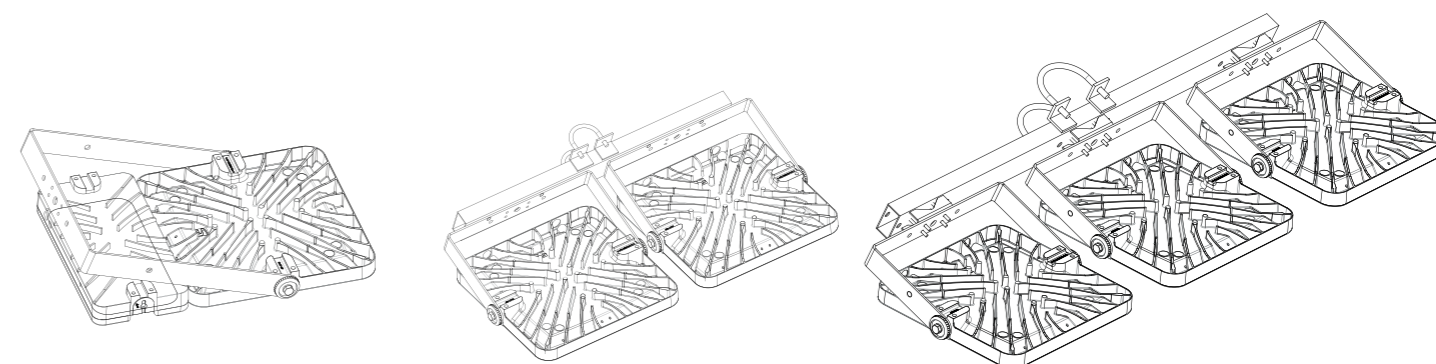

SIDE-ENTRY MONO

SIDE-ENTRY DUO

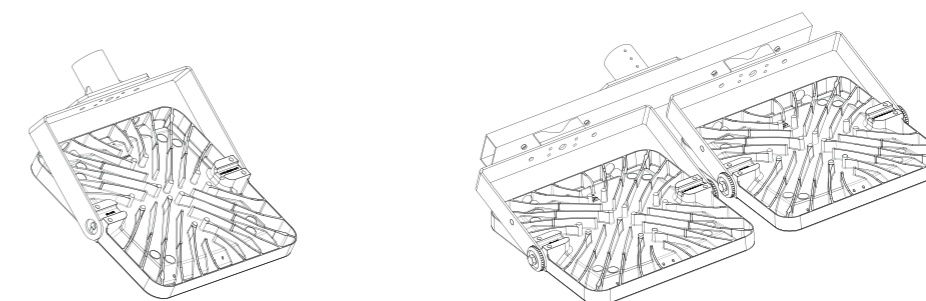

MAIN APPLICATIONS



MOTORWAY



LARGE AREAS



CAR PARK



LARGE ROUNDABOUT



MOTORWAY JUNCTION



LARGE PLACE

AMPERA

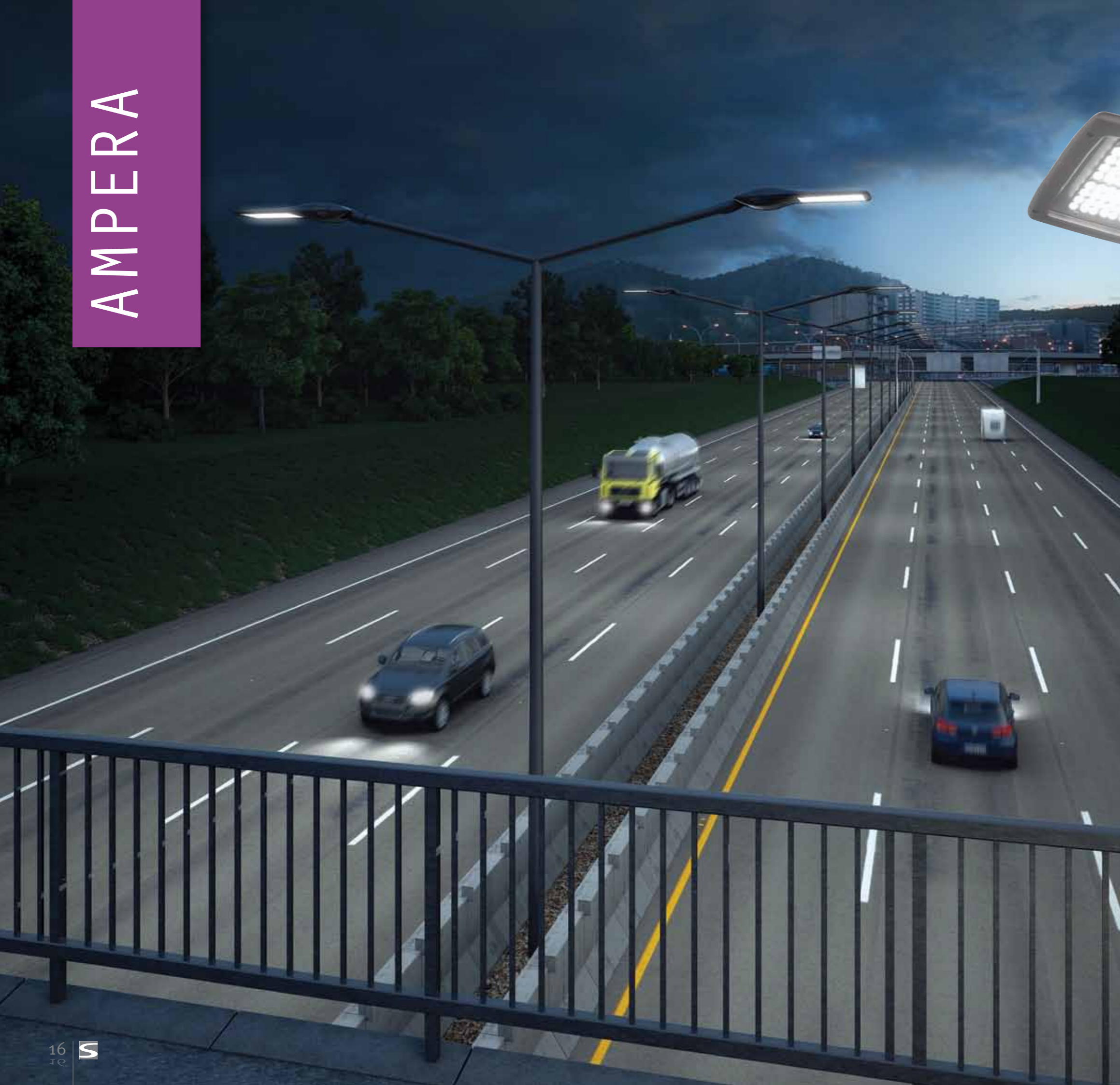

DESIGN
THOMAS COULBEAUT

LED SOLUTION FOR AN OPTIMISED RETURN ON INVESTMENT

DESIGNING THE MOST EFFICIENT AND COST-EFFECTIVE LED RANGE WAS THE DRIVING FORCE BEHIND THE DEVELOPMENT OF THE AMPERA FAMILY.

LED technology provides sustainable lighting solutions that can dramatically improve safety and well-being.

Nevertheless, a new lighting scheme requires a clear view on the total cost of ownership for the requested investment and the expected energy and maintenance savings.

The Ampera range sets a new benchmark in LED lighting with performing and flexible solutions that lead to the shortest payback time. With its long lifespan and limited maintenance requirements, the Ampera range enables you to maximise your return on investment.

Available in 3 sizes - with a lumen package scalable up to 31,100lm - and with numerous lighting distributions, the Ampera range can meet all your road and urban lighting needs.

This range is the perfect solution for replacing luminaires fitted with mercury vapour, high-pressure sodium, metal halide and other HID lamps. The Ampera Mini is a strategic alternative to fittings with 70W traditional light sources while the Ampera Midi and the Ampera Maxi provide significant energy savings for replacing luminaires with 150W and 250W lamps.



CHARACTERISTICS

Installation height	4 to 12m		
Lumen package range (nominal flux)	Mini 1,100 to 5,800lm	Midi 4,500 to 15,500lm	Maxi 11,400 to 31,100lm
Colour temperature	Cool, neutral or warm white		
Optical compartment tightness level	IP 66 (*)		
Control gear tightness level	IP 66 (*)		
Impact resistance (glass)	IK 09 (**)		
Nominal voltage	120 - 277V - 50 - 60Hz		
Electrical class	EU I or II (*)	US 1	
Materials			
Body	High-pressure die-cast aluminium		
Protector	Glass		
Colour	AKZO grey 900 sanded Any other RAL or AKZO colour upon request		

(*) according to IEC - EN 60598 – (**) according to IEC - EN 62262

»KEY ADVANTAGES

- Cost-effective and efficient lighting solution for a fast return on investment
- 3 sizes for flexibility
- IP 66 tightness level
- ThermiX®: withstands high temperatures (Ta 50°C)
- Mounting with two separated parts for easy installation and set-up (inclination angle)
- FutureProof: easy replacement of the photometric engine and gear compartment
- Surge protection 10kV

DIMENSIONS | MOUNTING

	Mini	Midi	Maxi
L	583mm	674mm	900mm
W	340mm	436mm	438mm
H	90mm	132mm	135mm

Universal mounting piece (side-entry and post-top):

- Ø 32mm with an adaptor
- Ø 48mm
- Ø 42 - 60mm
- Ø 76mm

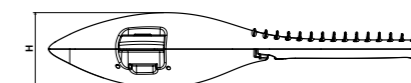
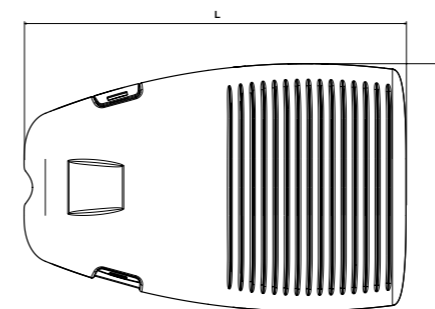
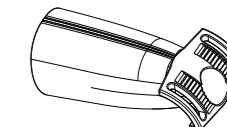

ANDO POLES AND BRACKETS

10M

6M

4M



MAIN APPLICATIONS



NARROW ROAD



RESIDENTIAL STREET



MOTORWAY



MEDIUM AREA



URBAN ROAD



LARGE AREA

NEOS ZEBRA LED



DESIGN
MICHEL TORTEL

THE BEST TOOL TO SECURE PEDESTRIAN CROSSINGS

THE NEOS ZEBRA LED WAS SPECIFICALLY DEVELOPED TO LIGHT PEDESTRIAN CROSSINGS.

Equipped with high-power LEDs, this luminaire has a focused light beam that creates a true contrast between the pedestrians and the surrounding environment to ensure that they are truly visible. The Neos Zebra LED is the perfect tool to increase safety for road users while saving energy.

Offering visual comfort for both motorists and pedestrians, the Neos Zebra LED helps them to share the public space more safely and more respectfully. It can dramatically reduce the frequency and the seriousness of accidents in critical zones such as school areas, heavy traffic roads or other dangerous situations.

The Neos Zebra LED is composed of a painted die-cast aluminium alloy housing fitted with a performing LED engine. Based on the OrientoFlex® concept, this engine maximises the luminous flux on the pedestrian crossing by meticulously orienting the LEDs. The Neos Zebra LED is sealed by a tempered glass and its inclination can be adjusted on-site.



owlet

CHARACTERISTICS

Installation height	4 to 6m
Lumen package range (nominal flux)	5,500lm
Colour temperature	Cool white (6,000K)
Number of LEDs	48 LEDs
Power consumption	60W
Luminaire tightness level	IP 66 (*)
Impact resistance	IK 08 (**)
Nominal voltage	230V - 50Hz
Electrical class	I (*)
Weight	12.6kg
MATERIALS	
Body + cover	Painted die-cast aluminium alloy
Protector	Tempered glass

(*) according to IEC - EN 60598 | (**) according to IEC - EN 62262

»»KEY ADVANTAGES

- Increased safety for pedestrians
- Visual comfort
- IP 66 tightness level for long-lasting performance
- Energy savings of 50% compared to traditional light sources
- Maintenance free
- High-quality and resistant materials
- Designed to incorporate Owllet range of control solutions

DIMENSIONS

L	520mm
W	500mm
H	160mm

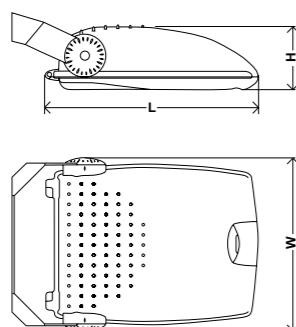

POLES AND BRACKETS

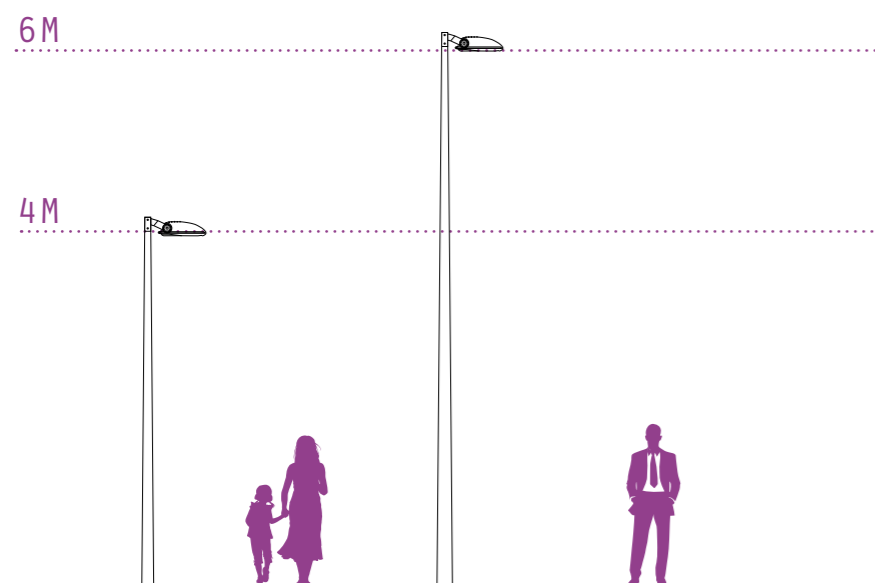

YOA



DESIGN
MICHEL TORTEL

ENERGY EFFICIENT URBAN LIGHTING SOLUTION WITH A TOUCH OF AMBIANCE

DESIGNED FOR URBAN APPLICATIONS, THE YOA LUMINAIRE PROVIDES A TOUCH OF AMBIANCE TO CREATE IDENTITY IN THE CITY LANDSCAPE.

Yoa is a contemporary interpretation of the classical range Citea - Maya - Scala – one of Schröder's best-sellers in urban lighting – based on LED technology. It is equipped with the second generation LensoFlex®2 photometric engine which offers a high-performance photometry optimised for each specific application with minimised energy consumption.

Built with recyclable materials - aluminium and glass - the Yoa luminaire is proposed in two sizes:

- **Yoa Midi** is particularly suited to lighting residential areas, urban roads, parks, squares, pedestrian zones,...
- **Yoa Maxi** is ideal for large avenues and main roads.

The Yoa range offers flexible combinations of LED modules, driving currents and dimming options to provide the most cost-effective solution while improving comfort and safety for people.

The Yoa is available for side-entry, post-top or suspended mounting.

A catenary version is also available.



CHARACTERISTICS

Installation height	4 to 10m
Lumen package range (nominal flux)	2,200 to 23,300lm
Colour temperature	Neutral or warm white
Optical compartment tightness level	IP 66 (*)
Control gear tightness level	IP 66 (*)
Impact resistance (glass)	IK 08 (**)
Nominal voltage	230V - 50Hz
Electrical class	I or II (*)
MATERIALS	
Body	Aluminium
Protector	Flat glass
Colour	Any RAL or AKZO colour

(*) according to IEC - EN 60598 | (**) according to IEC - EN 62262

KEY ADVANTAGES

- Maximised savings in energy and maintenance costs
- LensoFlex®2 offering high performance photometry, comfort and safety
- LED modules with flexible combinations of LEDs
- FutureProof
- ThermiX®
- Surge protection 10kV
- Designed to incorporate Owllet range of control solutions

DIMENSIONS

	Yoa Midi	Yoa Maxi
Ø	500mm	650mm
H	90mm	90mm

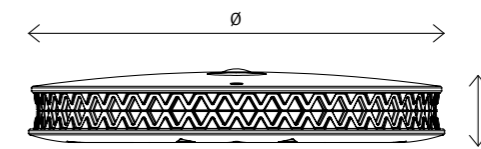

MOUNTING

The Yoa luminaire offers slip-over mounting onto a bracket with a 60mm diameter spigot (length 100mm).

A special bracket and pole for side-entry and post-top mounting are available (option).

TRESSA
(STANDARD SIDE-ENTRY)

LUCEA
(OPTIONAL SIDE-ENTRY)

LYRE
(OPTIONAL POST-TOP)



MAIN APPLICATIONS



NARROW ROAD



RESIDENTIAL STREET



MOTORWAY



URBAN ROAD



MEDIUM AREA



LARGE AREA

OPTIONS

- Catenary version
- Warm white LEDs

COLUMNS AND BRACKETS

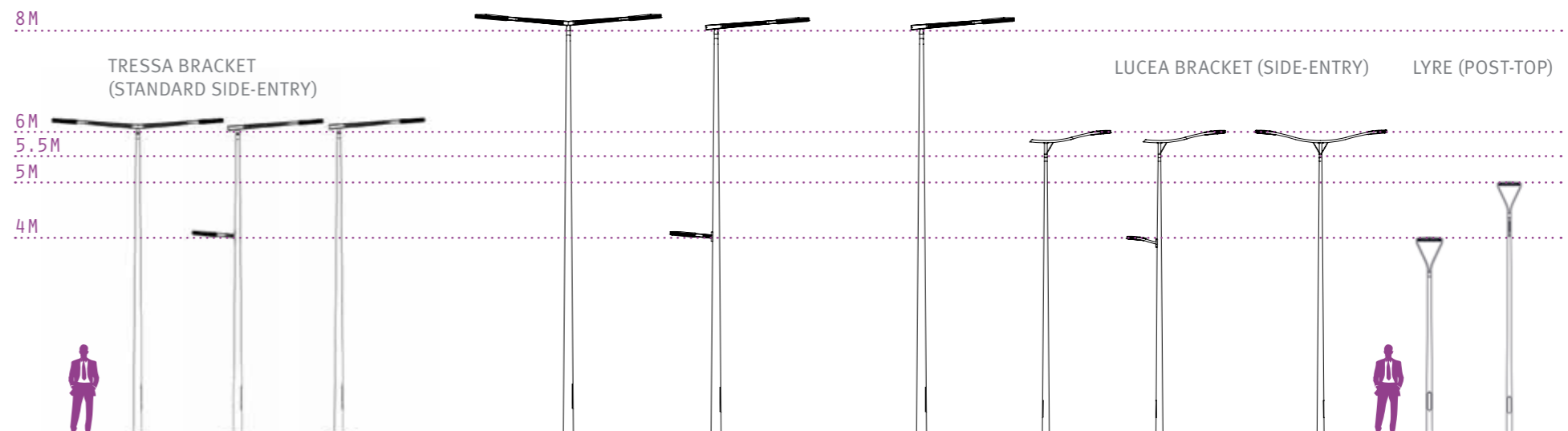

PILZEO



DESIGN
ACHILLES DESIGN

ELEGANT AND COST-EFFECTIVE SOLUTION WITH CUTTING-EDGE LED TECHNOLOGY

THE POST-TOP LUMINAIRE PILZEO TRANSFORMS THE CLASSIC 'MUSHROOM' LANTERN INTO A CONTEMPORARY DESIGN. BASED ON THE PROVEN LENSOFLEX®2 LED ENGINE, THE PILZEO ENSURES PHOTOMETRIC PERFORMANCE TO PROVIDE SAFETY AND WELL-BEING IN THE PUBLIC SPACE.

The Pilzeo luminaire is adapted to various urban landscapes such as residential areas, parks, squares, bicycle paths and historic urban centres. As a sustainable lighting tool, the Pilzeo makes it possible to achieve energy savings that can reach up to 75% compared with traditional luminaires.

The materials used are of excellent quality. The base section and body are made of high-pressure die-cast aluminium while the protector and the cover are composed of polycarbonate.

Thanks to the design of the Pilzeo luminaire, no tools are needed for any potential maintenance operations.



CHARACTERISTICS

Installation height	3.5 to 5m
Lumen package range (nominal flux)	1,900 to 5,800lm
Colour temperature	Neutral or warm white
Optical compartment tightness level	IP 66 ^(*)
Control gear tightness level	IP 66 ^(*)
Impact resistance (glass)	IK 08 ^(**)
Nominal voltage	230V - 50Hz
Electrical class	I or II ^(*)
MATERIALS	
Cover	Polycarbonate
Base section	High-pressure die-cast aluminium
Gear tray	High-pressure die-cast aluminium
Protector	Polycarbonate
Colour	AKZO grey 900 sanded

^(*) according to IEC - EN 60598 | ^(**) according to IEC - EN 62262

»»KEY ADVANTAGES

- Cost-effective lighting solution for creation of ambiance
- Elegant design for low height installation
- No tools needed for maintenance operations
- IP 66 tightness level for long lasting performance
- Surge protection 10kV
- Designed to incorporate Owllet range of control solutions

MAIN APPLICATIONS



DIMENSIONS

W	524mm
H	530mm

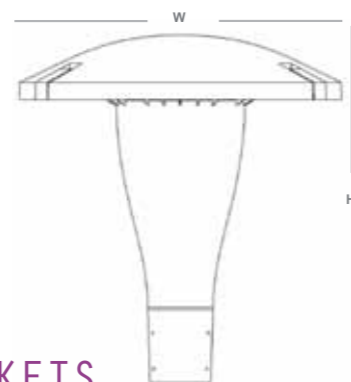

Fixation on Ø 76mm pole (3 x 2 M6 screws)

COLUMNS AND BRACKETS

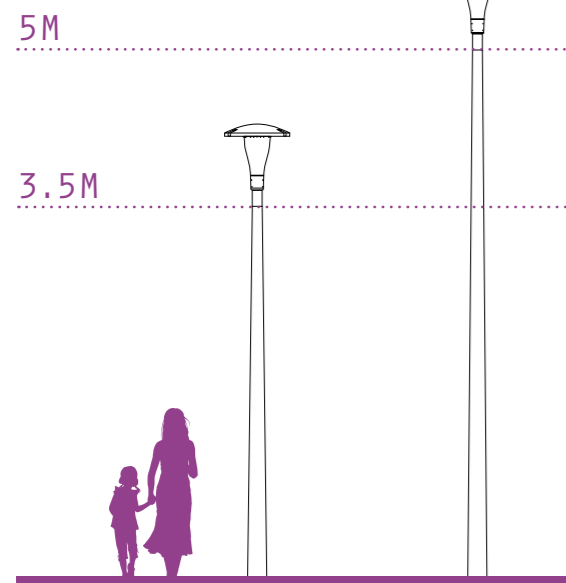

RESIDENTIAL STREET



SQUARE



NARROW ROAD



DEXO



DESIGN
THOMAS COULBEAUT

A MODERN IDENTITY FOR EFFICIENT CATENARY LED LIGHTING

THE DEXO LUMINAIRE USES STATE-OF-THE-ART LED TECHNOLOGY TO PROVIDE COST-EFFECTIVE LIGHTING FOR URBAN CATENARY APPLICATIONS.

The combination of a pure and elegant design with the high performance LensoFlex®2 LED photometric engine increases safety and comfort while creating a distinctive identity in the city.

Made of robust and recyclable materials - die-cast aluminium and glass - the DEXO is available in three versions:

- 32 LEDs
- 48 LEDs
- 64 LEDs

It offers efficient lighting with dramatic energy savings compared with luminaires equipped with traditional light sources. The DEXO can be equipped with its suspension in transversal or axial orientation to suit most applications in urban lighting.

The flexible combinations of LED configurations, driving currents and dimming options make the DEXO a perfect tool for improving safety and comfort while reducing the ecological footprint.



CHARACTERISTICS

Mounting height	7 to 10m
Lumen package range (nominal flux)	4,400 to 12,000lm
Colour temperature	Neutral or warm white
Tightness level	IP 66 (*)
Impact resistance (glass)	IK 08 (**)
Nominal voltage	230V - 50Hz
Electrical class	I or II (*)
Weight	11.5kg
MATERIALS	
Body	Aluminium
Protector	Flat glass
Colour	RAL 9006s (structured) Other RAL or AKZO colours upon request

»»KEY ADVANTAGES

- Maximised savings in energy and maintenance costs
- The right light through LensoFlex®2 offering high performance photometry, comfort and safety
- Symmetrical light distribution
- FutureProof: photometric engine and electronic assembly are easy to replace
- Durable and recyclable materials
- Surge protection 10kV

(*) according to IEC - EN 60598 | (**) according to IEC - EN 62262

DIMENSIONS

W	352mm
L	672mm
H1	196mm
H2	282mm

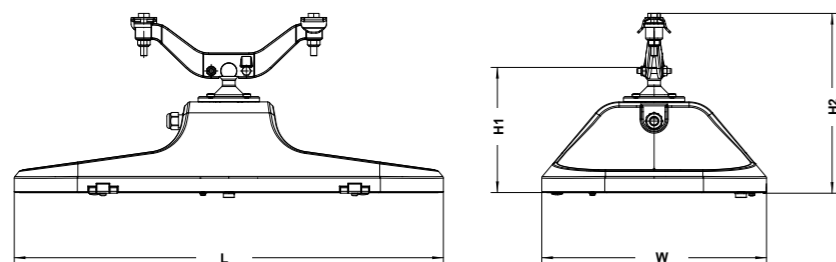

MOUNTING

- Standard fixation up to rope-diameter 12mm
- Fixation with external electrical connection is also available
- Rope fixing: rotation 90°
tilt 15°

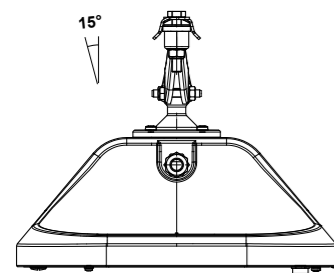

MAIN APPLICATION



STREET





SAFETY



WELL-BEING



SUSTAINABILITY



SAVINGS



SOLUTIONS

